

Pioneer

EFFECTOR

EFX-500

Operating instructions

Thank you for purchasing this Pioneer product. Be sure to read these operating instructions before using your unit to prevent any damage that may result from improper operation. Once you have finished reading the instructions, place them in a safe place where they won't become lost and can be easily accessed for future reference.

IMPORTANT 1



The lightning flash with arrowhead symbol, within an equilateral triangle, is intended to alert the user to the presence of uninsulated "dangerous voltage" within the product's enclosure that may be of sufficient magnitude to constitute a risk of electric shock to persons.



CAUTION:
TO PREVENT THE RISK OF ELECTRIC SHOCK, DO NOT REMOVE COVER (OR BACK). NO USER-SERVICEABLE PARTS INSIDE. REFER SERVICING TO QUALIFIED SERVICE PERSONNEL.



The exclamation point within an equilateral triangle is intended to alert the user to the presence of important operating and maintenance (servicing) instructions in the literature accompanying the appliance.

IMPORTANT SAFETY INSTRUCTIONS

READ INSTRUCTIONS — All the safety and operating instructions should be read before the product is operated.

RETAIN INSTRUCTIONS — The safety and operating instructions should be retained for future reference.

HEED WARNINGS — All warnings on the product and in the operating instructions should be adhered to.

FOLLOW INSTRUCTIONS — All operating and use instructions should be followed.

CLEANING — The product should be cleaned only with a polishing cloth or a soft dry cloth. Never clean with furniture wax, benzene, insecticides or other volatile liquids since they may corrode the cabinet.

ATTACHMENTS — Do not use attachments not recommended by the product manufacturer as they may cause hazards.

WATER AND MOISTURE — Do not use this product near water — for example, near a bathtub, wash bowl, kitchen sink, or laundry tub; in a wet basement; or near a swimming pool; and the like.

ACCESSORIES — Do not place this product on an unstable cart, stand, tripod, bracket, or table. The product may fall, causing serious injury to a child or adult, and serious damage to the product. Use only with a cart, stand, tripod, bracket, or table recommended by the manufacturer, or sold with the product. Any mounting of the product should follow the manufacturer's instructions, and should use a mounting accessory recommended by the manufacturer.

CART — A product and cart combination should be moved with care. Quick stops, excessive force, and uneven surfaces may cause the product and cart combination to overturn.



VENTILATION — Slots and openings in the cabinet are provided for ventilation and to ensure reliable operation of the product and to protect it from overheating, and these openings must not be blocked or covered. The openings should never be blocked by placing the product on a bed, sofa, rug, or other similar surface. This product should not be placed in a built-in installation such as a bookcase or rack unless proper ventilation is provided or the manufacturer's instructions have been adhered to.

POWER SOURCES — This product should be operated only from the type of power source indicated on the marking label. If you are not sure of the type of power supply to your home, consult your product dealer or local power company.

LOCATION — The appliance should be installed in a stable location.

NONUSE PERIODS — The power cord of the appliance should be unplugged from the outlet when left unused for a long period of time.

GROUNDING OR POLARIZATION

- If this product is equipped with a polarized alternating current line plug (a plug having one blade wider than the other), it will fit into the outlet only one way. This is a safety feature. If you are unable to insert the plug fully into the outlet, try reversing the plug. If the plug should still fail to fit, contact your electrician to replace your obsolete outlet. Do not defeat the safety purpose of the polarized plug.

- If this product is equipped with a three-wire grounding type plug, a plug having a third (grounding) pin, it will only fit into a grounding type power outlet. This is a safety feature. If you are unable to insert the plug into the outlet, contact your electrician to replace your obsolete outlet. Do not defeat the safety purpose of the grounding type plug.

POWER-CORD PROTECTION — Power-supply cords should be routed so that they are not likely to be walked on or pinched by items placed upon or against them, paying particular attention to cords at plugs, convenience receptacles, and the point where they exit from the product.

OUTDOOR ANTENNA GROUNDING — If an outside antenna or cable system is connected to the product, be sure the antenna or cable system is grounded so as to provide some protection against voltage surges and built-up static charges. Article 810 of the National Electrical Code, ANSI/NFPA 70, provides information with regard to proper grounding of the mast and supporting structure, grounding of the lead-in wire to an antenna discharge unit, size of grounding conductors, location of antenna-discharge unit, connection to grounding electrodes, and requirements for the grounding electrode. See Figure A.

LIGHTNING — For added protection for this product during a lightning storm, or when it is left unattended and unused for long periods of time, unplug it from the wall outlet and disconnect the antenna or cable system. This will prevent damage to the product due to lightning and power-line surges.

POWER LINES — An outside antenna system should not be located in the vicinity of overhead power lines or other electric light or power circuits, or where it can fall into such power lines or circuits. When installing an outside antenna system, extreme care should be taken to keep from touching such power lines or circuits as contact with them might be fatal.

OVERLOADING — Do not overload wall outlets, extension cords, or integral convenience receptacles as this can result in a risk of fire or electric shock.

OBJECT AND LIQUID ENTRY — Never push objects of any kind into this product through openings as they may touch dangerous voltage points or short-out parts that could result in a fire or electric shock. Never spill liquid of any kind on the product.

SERVICING — Do not attempt to service this product yourself as opening or removing covers may expose you to dangerous voltage or other hazards. Refer all servicing to qualified service personnel.

DAMAGE REQUIRING SERVICE — Unplug this product from the wall outlet and refer servicing to qualified service personnel under the following conditions:

- When the power-supply cord or plug is damaged.
- If liquid has been spilled, or objects have fallen into the product.
- If the product has been exposed to rain or water.
- If the product does not operate normally by following the operating instructions. Adjust only those controls that are covered by the operating instructions as an improper adjustment of other controls may result in damage and will often require extensive work by a qualified technician to restore the product to its normal operation.
- If the product has been dropped or damaged in any way.
- When the product exhibits a distinct change in performance — this indicates a need for service.

REPLACEMENT PARTS — When replacement parts are required, be sure the service technician has used replacement parts specified by the manufacturer or have the same characteristics as the original part. Unauthorized substitutions may result in fire, electric shock, or other hazards.

SAFETY CHECK — Upon completion of any service or repairs to this product, ask the service technician to perform safety checks to determine that the product is in proper operating condition.

WALL OR CEILING MOUNTING — The product should not be mounted to a wall or ceiling.

HEAT — The product should be situated away from heat sources such as radiators, heat registers, stoves, or other products (including amplifiers) that produce heat.

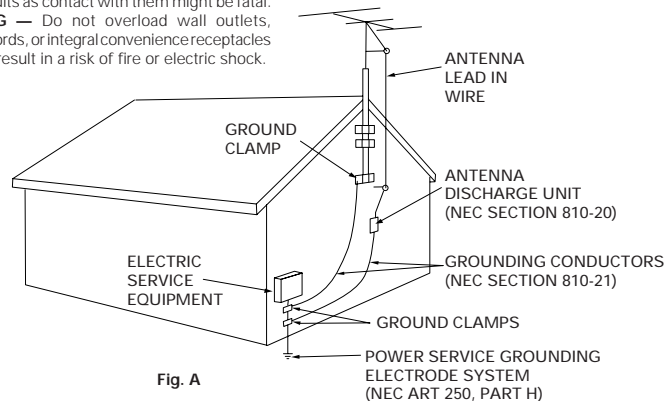

Fig. A

NEC — NATIONAL ELECTRICAL CODE

WARNING: TO PREVENT FIRE OR SHOCK HAZARD, DO NOT EXPOSE THIS APPLIANCE TO RAIN OR MOISTURE.

IMPORTANT NOTICE

The serial number for this equipment is located on the bottom plate. Please write this serial number on your enclosed warranty card and keep it in a secure area. This is for your security.

[For Canadian model]

CAUTION: TO PREVENT ELECTRIC SHOCK DO NOT USE THIS (POLARIZED) PLUG WITH AN EXTENSION CORD, RECEPTACLE OR OTHER OUTLET UNLESS THE BLADES CAN BE FULLY INSERTED TO PREVENT BLADE EXPOSURE.

ATTENTION: POUR PREVENIR LES CHOCS ELECTRIQUES NE PAS UTILISER CETTE FICHE POLARISEE AVEC UN PROLONGATEUR, UNE PRISE DE COURANT OU UNE AUTRE SORTIE DE COURANT, SAUF SI LES LAMES PEUVENT ETRE INSEREES A FOND SANS EN LAISSER AUCUNE PARTIE A DECOUVERT.

CAUTION: This product satisfies FCC regulations when shielded cables and connectors are used to connect the unit to other equipment. To prevent electromagnetic interference with electric appliances such as radios and televisions, use shielded cables and connectors for connections.

[For Canadian model]

This Class B digital apparatus meets all requirements of the Canadian Interference-Causing Equipment Regulations.

[Pour le modèle Canadien]

Cet appareil numérique de la Classe B respecte toutes les exigences du Règlement sur le matériel brouilleur du Canada.

Information to User

Alteration or modifications carried out without appropriate authorization may invalidate the user's right to operate the equipment.

FEATURES

■ **3-band beat effector function**

The highly acclaimed auto BPM counter/beat effect in DJM-500 has been substantially improved. Effects can now be applied only to the sound in the selected band and be adjusted in time with the tempo (BPM) of the tune. This provides greater means of expression than the previous effector that operated across the entire band.

■ **DIGITAL JOG BREAK function**

The jog dial gives you real-time control over the sound effects. Eight seconds of jog operation is stored to allow replay. A total of 25 effects including a beat effect are provided.

■ **High-performance 3-band Isolator Function [Fourth-order filter (-24 dB/oct.)]**

Level control is possible between +6 dB to $-\infty$ and a separation of up to -24 dB/oct. for each band ensure accurate sound reproduction.

■ **Input and Effect Out Peak Level Monitor**

Since both input and effect output levels can be visually assessed, precise level settings can be made without any time loss.

■ **MIDI In/Out Function**

External MIDI signals (timing clock signals) make it possible to synchronize the beat effector and convert BPM values that have been manually set or automatically measured from the music to MIDI timing clock signals to operate external sequencers or similar instruments.

■ **High-quality Design**

The effector uses 20-bit A/D, D/A (48 kHz sampling) conversion and 24-bit DSP.

BLOCK DIAGRAM

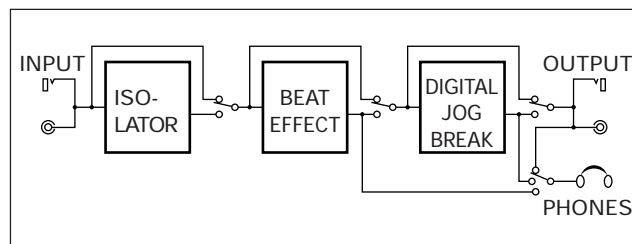

CONTENTS

BEFORE USE

IMPORTANT SAFETY INSTRUCTIONS 2
FEATURES 3
QUICK OPERATION GUIDE 4
SOUND EFFECTS 6
CONNECTIONS 8
NAMES OF PARTS AND FUNCTIONS 10

OPERATIONS 12

ADJUSTING INPUT LEVEL 12
ADJUSTING EFFECT OUTPUT LEVEL 12
HEADPHONE MONITOR 13
ISOLATOR 13
BEAT EFFECT 14
DIGITAL JOG BREAK 16
JOG MEMORY 17
MIDI SETTINGS 18

TROUBLESHOOTING AND SPECIFICATIONS

TROUBLESHOOTING 19
SPECIFICATIONS 19

QUICK OPERATION GUIDE

ADJUSTING THE INPUT LEVEL

Input signals to the input terminal and turn the INPUT LEVEL dial to the position right before the "OVER" (red) indicator lights.

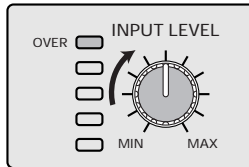

USING THE ISOLATOR

1. Use the three dials, LOW, MID and HI to set respective levels. (Each $-\infty$ setting produces no sound.)
2. Press the ISOLATOR lever towards you (ON position) to start operation; release it and it returns to the center position (OFF position). At the center position (OFF position), the signal is output as is regardless of dial setting. Press the lever away from you to lock it in position so that the isolator operates also when the lever is released.

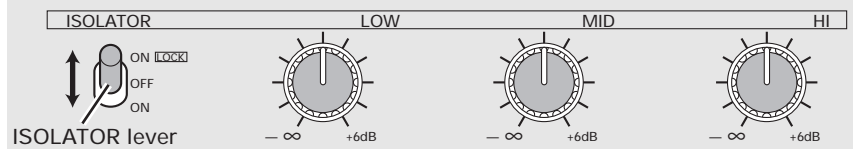

USING BEAT EFFECTS

1. Select BPM measurement mode.

Press the BPM MODE button to light an indicator (AUTO, MIDI or TAP) on the indicator panel.

2. Select effect type.

Press the DELAY, ECHO, PAN, FLANGER or TRANS button and the pressed button starts to flash.

3. Select EFFECT FREQUENCY.

Press the button of the frequency (LOW, MID, HI) you wish to affect by the beat effect and the corresponding indicator lights.

4. Select the beat with which the effect is to be synchronized.

Press a beat button (1/4, 1/2, 3/4, 1/1, 2/1 or 4/1) to light the desired button.

5. Apply an effect.

Press the lever towards you (ON position) to start operation; release it and it returns to the center position (OFF position). In the center position (OFF position), the original sound is not affected. Press the lever away from you to lock it in position so that the beat effect is applied also when the lever is released.

TIME/BPM Dial

Set the desired effect time as in step 4. Turn the TIME/BPM dial while holding down the TAP/SHIFT button to make the desired BPM setting. When also the BPM MODE button is held down, BPM can be set in 0.1 increments.

TAP button

BPM can be manually adjusted by adjusting the beat (quarter notes) and hitting this key two times or more.

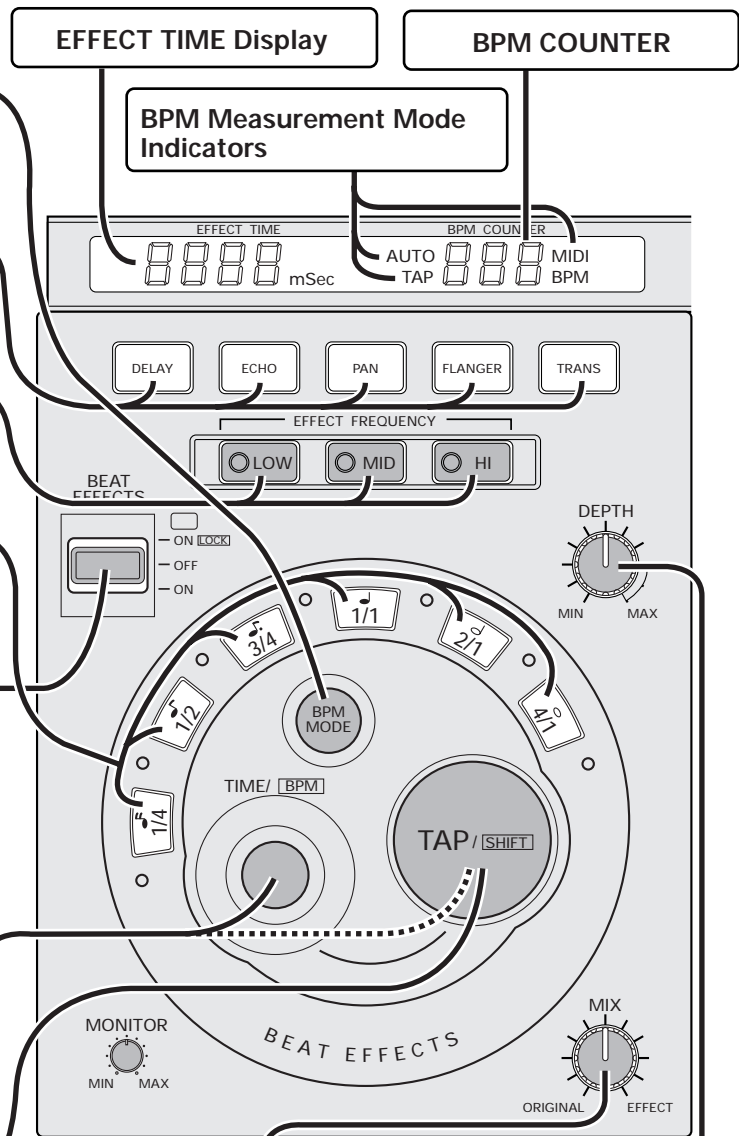

MIX Dial

Sets the balance between the original sound and effects.

DEPTH Dial

Sets the parameter of each effect.

ADJUSTING EFFECT OUTPUT LEVEL

Turn the EFFECT OUT LEV dial to the position right before the "OVER" (red) indicator lights.

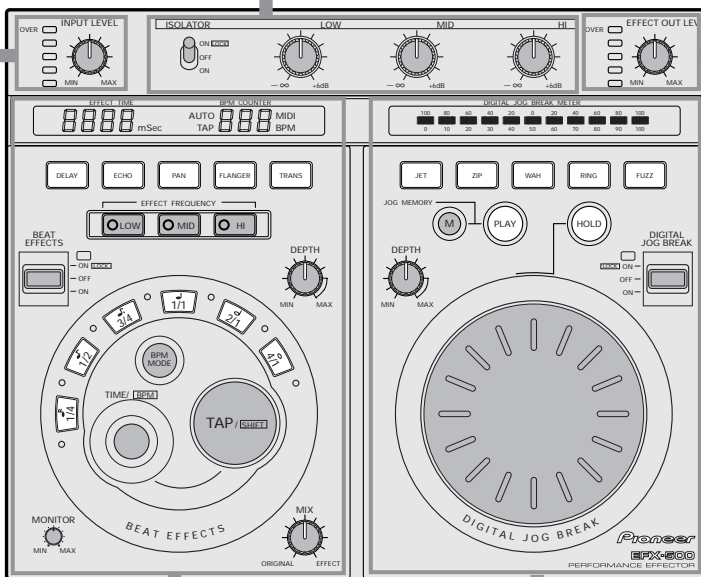
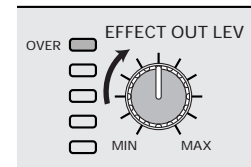

USING THE DIGITAL JOG BREAK

DIGITAL JOG BREAK METER

Indicates the amount of control exercised by the Jog dial. (→ page 16)

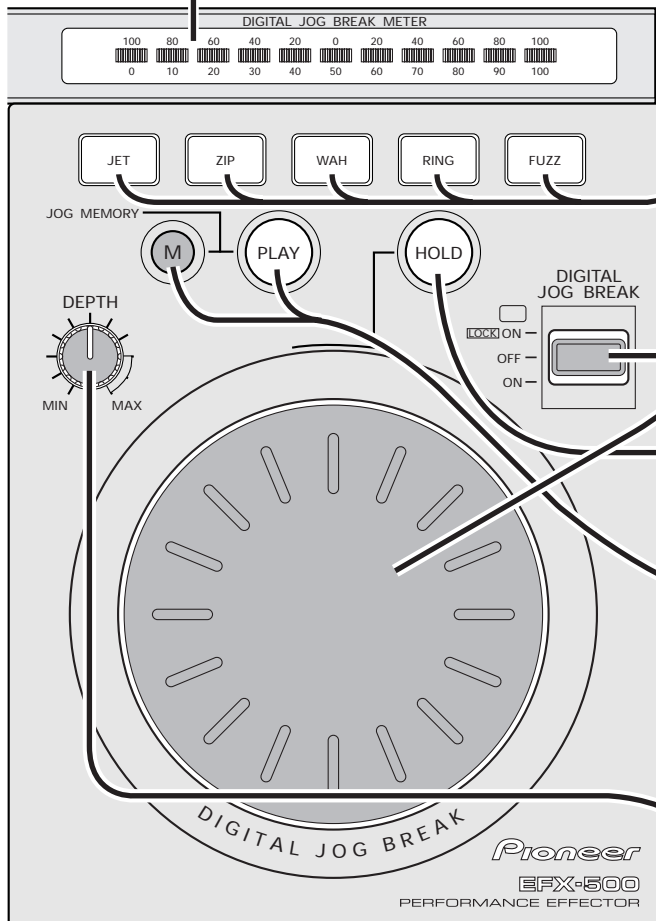

1. Select the desired effect.

Press the desired effect button, JET, ZIP, WAH, RING or FUZZ to flash the corresponding button.

2. Apply the desired effect.

Turn the Jog dial either while pressing the lever towards you or pressing it away from you (ON position). As the jog dial is turned, parameters change gradually and the selected effect is applied. When the dial rotation is stopped, the parameter returns to normal. When the lever is pressed towards you, releasing it causes it to automatically return to the center (OFF position).

HOLD Button

When this button is pressed and is lit, the effect is maintained when jog dial rotation is stopped.

Memory (M) Button/PLAY Button

Jog dial operation for up to 8 seconds can be stored in memory by holding down the Memory (M) button during Jog dial operation. Jog dial operation stored in the memory can be recalled with the PLAY button.

DEPTH Dial

Sets the parameter of each effect. (→ pages 7, 16)

SOUND EFFECTS

BEAT EFFECT

1. DELAY

Adds a delayed sound to the original sound.

- The DEPTH dial allows you to adjust the feedback level. Feedback is the return of delayed sound to the delayed input. The amount of sound returned can be adjusted (the level increases as the setting approaches the "MAX" position).

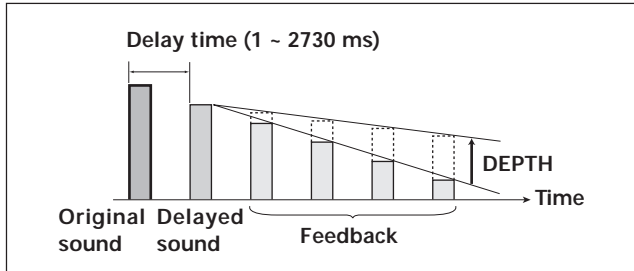

BEAT EFFECTS Lever Switch Position

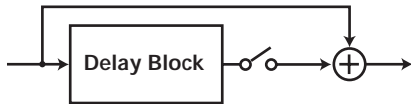

- The MIX dial adjusts the balance of original sound and delayed sound levels.

2. ECHO

Adds a delayed sound to the original sound.

This effect differs from DELAY in the following respects.

- Feedback continues even when the BEAT EFFECTS lever switch is moved from "ON" to "OFF".
- When the DEPTH dial is set to "MAX" and the Lever switch is set from "ON" to "OFF", the feedback does not attenuate but produces a whole delay effect (the level increases as the setting approaches the "MAX" position).

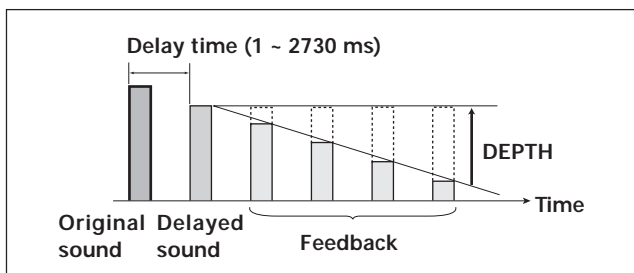

BEAT EFFECTS Lever Switch Position



3. PAN

Produces a cyclic change in the stereo orientation.

- The DEPTH dial allows you to change the stereo orientation.

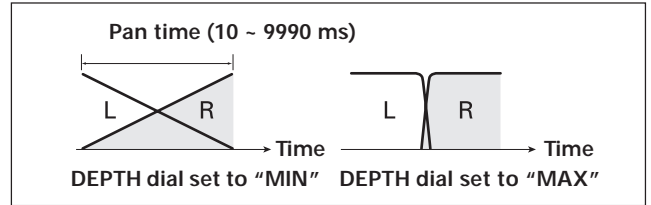

- Original sound and pan sound levels can be changed using the MIX dial. The pan value is 100% at the center clicked position.

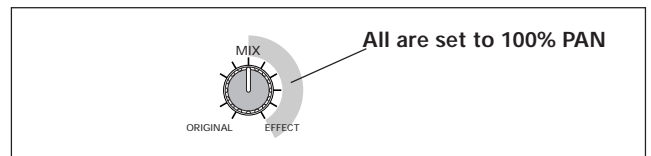

4. FLANGER

Produces the sound of an ascending or descending jet plane.

- The DEPTH dial allows you to change the feedback level. Raising the feedback level increases the typical undulating characteristics of the flanger effect which at "MAX" level changes to an oscillating sound (the level increases as the setting approaches the "MAX" position).
- The MIX dial adjusts the balance of original sound and flanger sound levels.

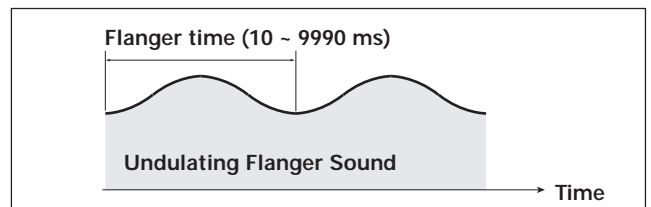

5. TRANS

Cuts off the sound cyclically.

- The proportion of the sound cut off can be varied with the DEPTH dial.

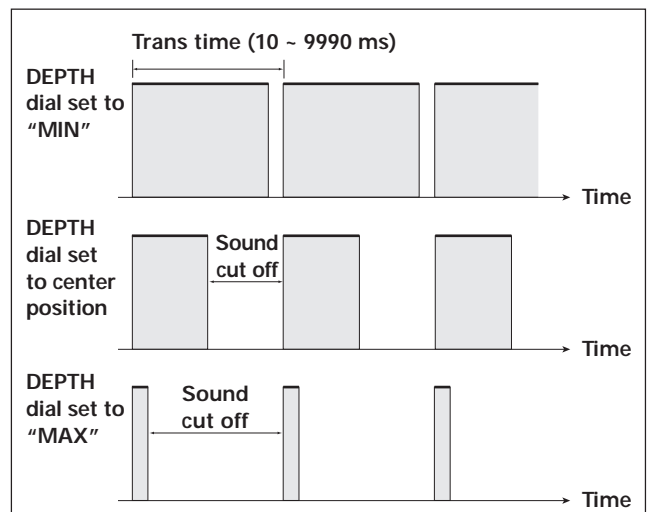

- The MIX dial adjusts the balance of original sound and trans sound levels.

DIGITAL JOG BREAK

1. JET

Produces the sound of an ascending or descending jet plane.

- Use the Jog dial to change the undulating tone.

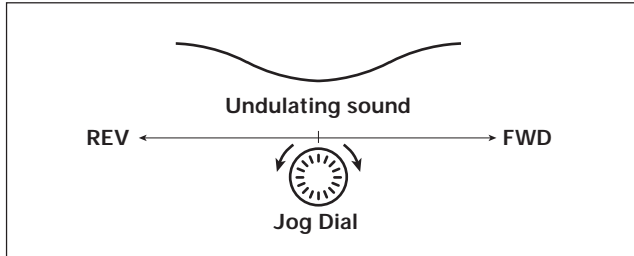

- The DEPTH dial allows you to change the feedback level. Raising the feedback level increases the undulating characteristics which changes to an oscillating sound at "MAX" level (the level increases as the setting approaches the "MAX" position).

2. ZIP

Use the Jog dial to change the pitch.

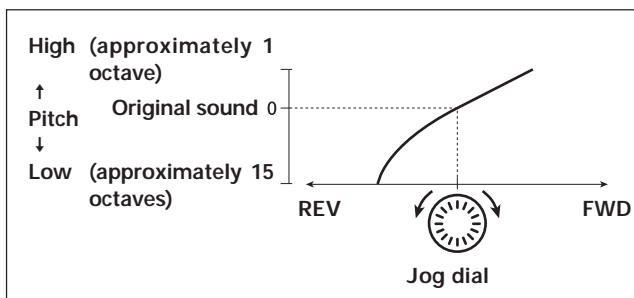

- The DEPTH dial is used to change the mix of the original sound and the pitch change. The pitch sound is 100% at the center clicked position.

3. WAH

This effect causes a major pitch change by changing filter frequency.

- The Jog dial is used to change the filter frequency.

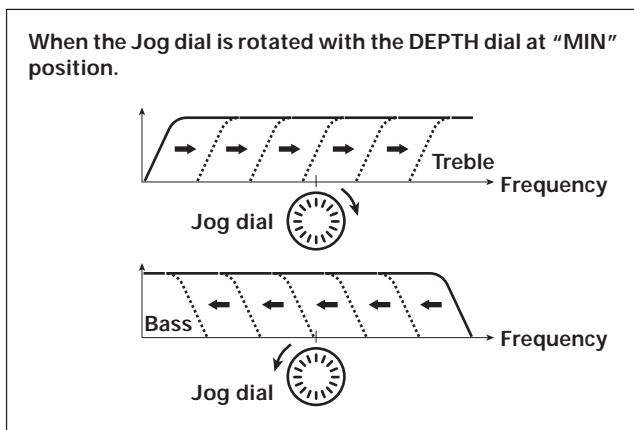

- The DEPTH dial is used to change filter characteristics and thereby emphasize the tone color (the level increases as the setting approaches the "MAX" position).

Changing filter characteristics using the DEPTH dial

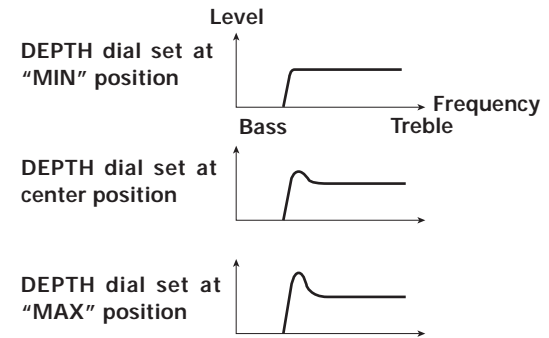

4. RING

This effect changes the shape of the sine wave of the original sound to create a bell-like sound.

- The Jog dial is used to change sine wave frequency.

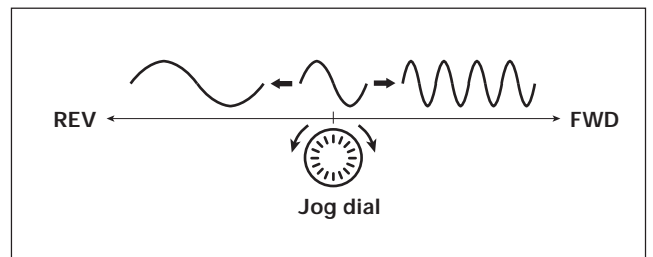

- The DEPTH dial is used to change the mix of the original sound and the ring modulator sound.

5. FUZZ

This effect distorts a specific sound in the original sound source.

- The Jog dial is used to select the band that is to be distorted.

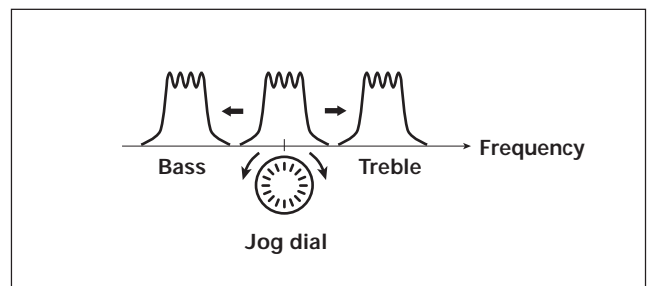

- The DEPTH dial changes the amount of distortion that is applied (the level increases as the setting approaches the "MAX" position).

CONNECTIONS

■ Before making or changing the connections, switch off the power switch and disconnect the power cord from the AC outlet. This precaution should also be taken when changing the IN & OUT LEVEL switch.

- When connections are made to the phone jack inputs and a monaural signal cord is connected to the L (MONO) terminal, inputs can be made to both the L and R channels.
- After all other connections are made, connect the power cord to a household wall outlet or to the auxiliary AC power take-off on your amplifier.
- Make sure plugs are fully inserted into the jacks and wall outlet.

■ See page 18 for instructions on how to use the MIDI terminals.

CAUTION: Do not make any connections that may create signal loops as this will cause circuit oscillations which could damage the speakers.

Example of connections that must not be performed.

- Do not connect the output of the DJ Mixer to the input terminal of the Effector and the output of the Effector to the input terminal of the same mixer.
- Do not connect the SEND output of the DJM-500 to the input terminal of the Effector and the output of the Effector to the input terminal of the DJM-500 (except for the RETURN terminal).

POWER-CORD CAUTION

Handle the power cord by the plug. Do not pull out the plug by tugging the cord and never touch the power cord when your hands are wet as this could cause a short circuit or electric shock. Do not place the unit, a piece of furniture, etc., on the power cord, or pinch the cord. Never make a knot in the cord or tie it with other cords. The power cords should be routed such that they are not likely to be stepped on. A damaged power cord can cause a fire or give you an electrical shock. Check the power cord once in a while. When you find it damaged, ask your nearest PIONEER authorized service center or your dealer for a replacement.

BASIC CONNECTIONS

1. Connecting the SEND/RETURN Terminals on the DJ Mixer (on DJ mixer provided with SEND and RETURN terminals)

- Make connections using cables with 1/4-inch/6.3 mm in diameter phone plugs.
- Set the DJ mixer so that the SEND and RETURN terminals can be used. (Make sure that the EFFECT SELECTOR, CH SELECTOR and EFFECT ON/OFF on the DJM-500 are correctly set).

- Set the IN & OUT LEVEL switch on the Effector to the -10 dB position.

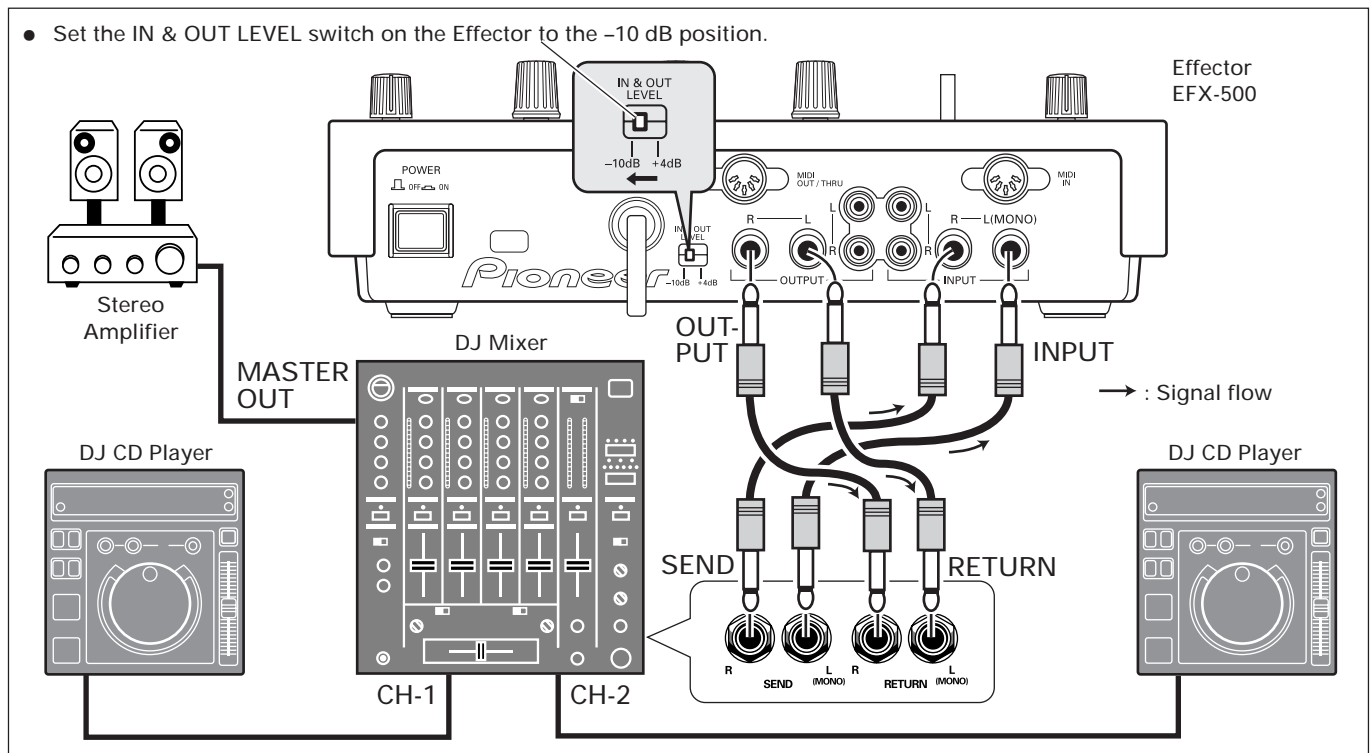

Installation guidelines

- Placing and using the unit for long periods on heat-generating sources such as amplifiers or near spotlights, etc. will affect product performance. Avoid placing the player on heat-generating sources.
- Install this unit as far as possible away from tuners and TV sets. A unit installed in close proximity to such equipment may cause noise or degradation of the picture.
- Noise may be noticeable when an indoor antenna is used. In such cases, make use of an outdoor antenna or turn off power to the unit.

Cleaning the unit

To clean the unit wipe with a polishing or a soft, dry cloth. For stubborn dirt, moisten a soft cloth with a weak solution of neutral detergent (diluted in five to six parts water), wring the cloth well, and wipe away the dirt. Use a dry cloth to wipe the surface dry. Do not use volatile liquids such as benzene or thinner which will damage to the unit.

2. Connecting a DJ Mixer and an Audio Amplifier (on DJ mixer not provided with SEND and RETURN terminals)

- Connect using cables with phone plugs (1/4-inch/6.3 mm in diameter) or RCA pin plugs.

- Do not connect two units using both RCA pin plug and phone plug cords (use only type of connection).

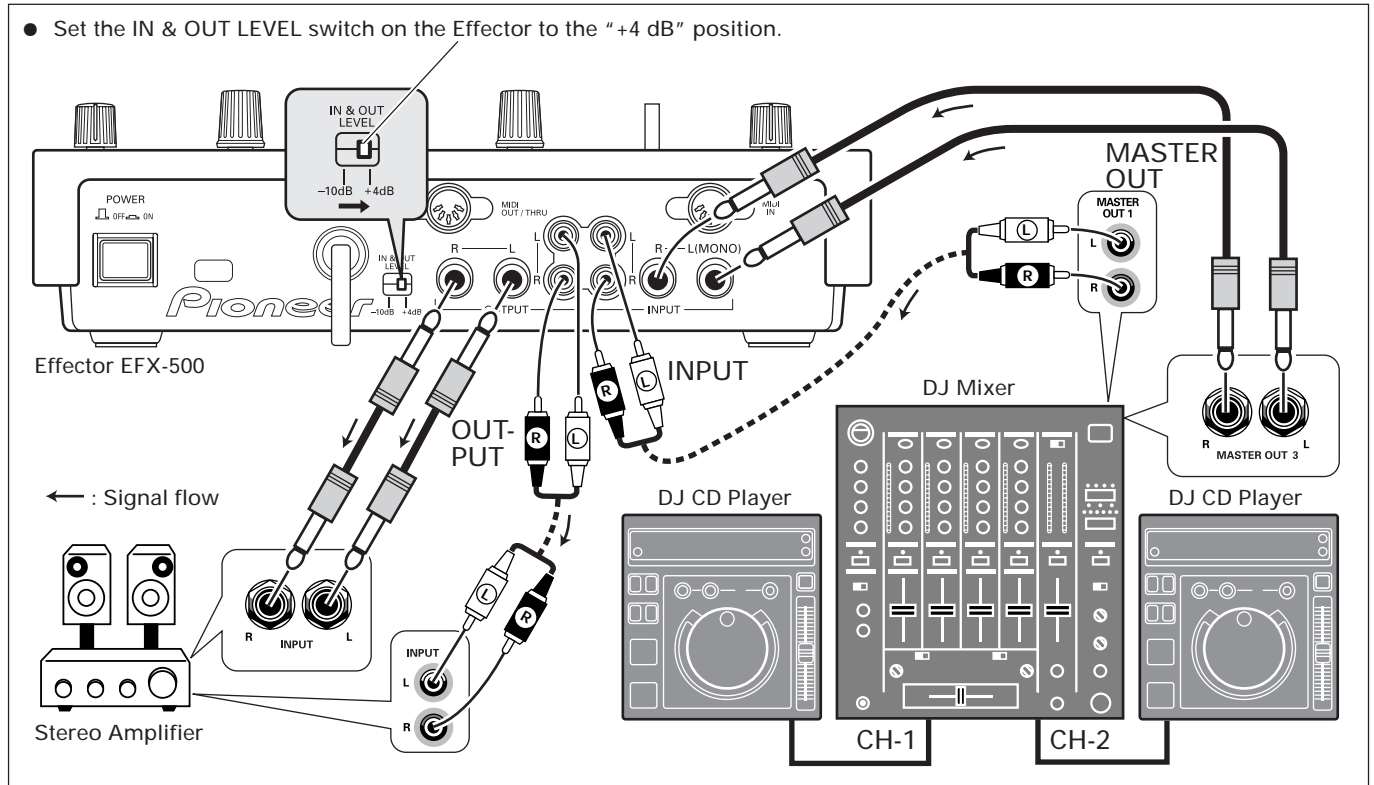

3. Connecting a DJ CD Player and a DJ Mixer (this connection applies effects only to the sound of the DJ CD player on channel 2)

- Connect the units using a cable with RCA pin plugs

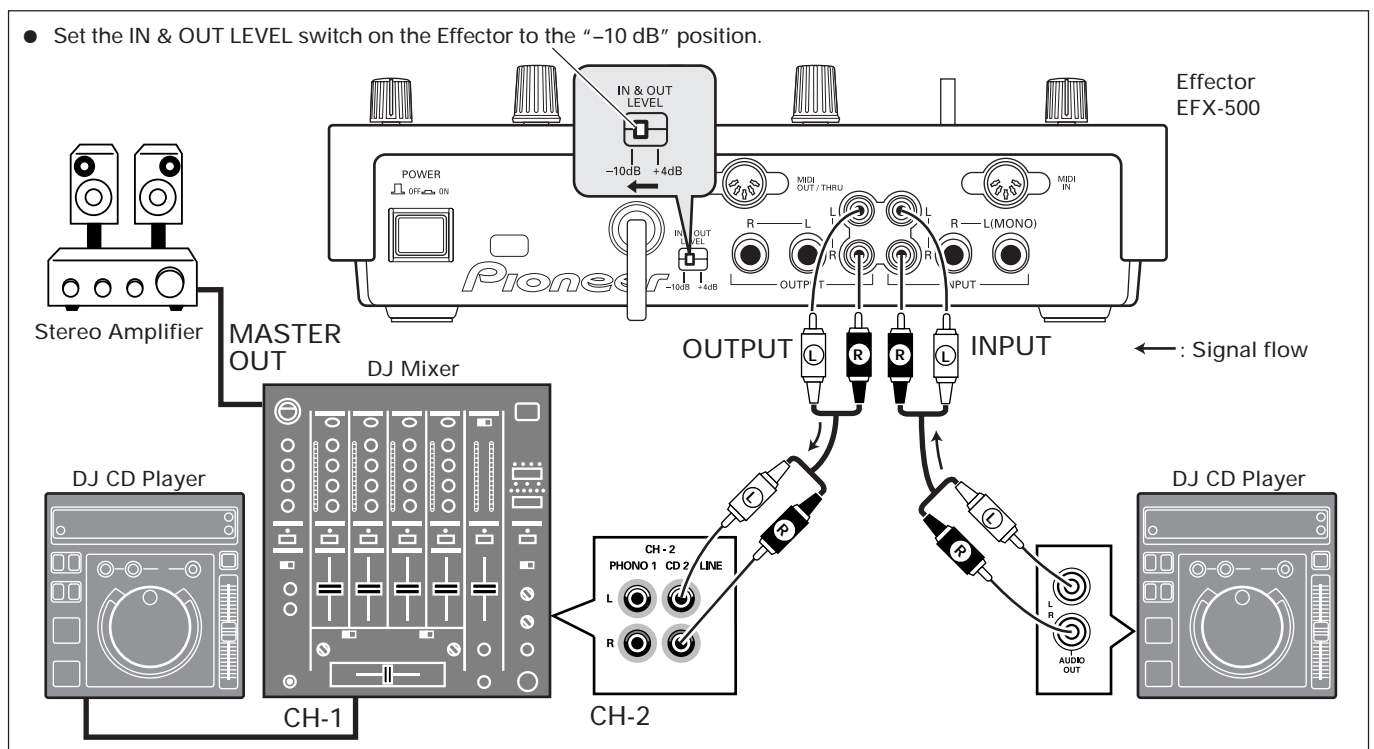

NAMES OF PARTS AND FUNCTIONS

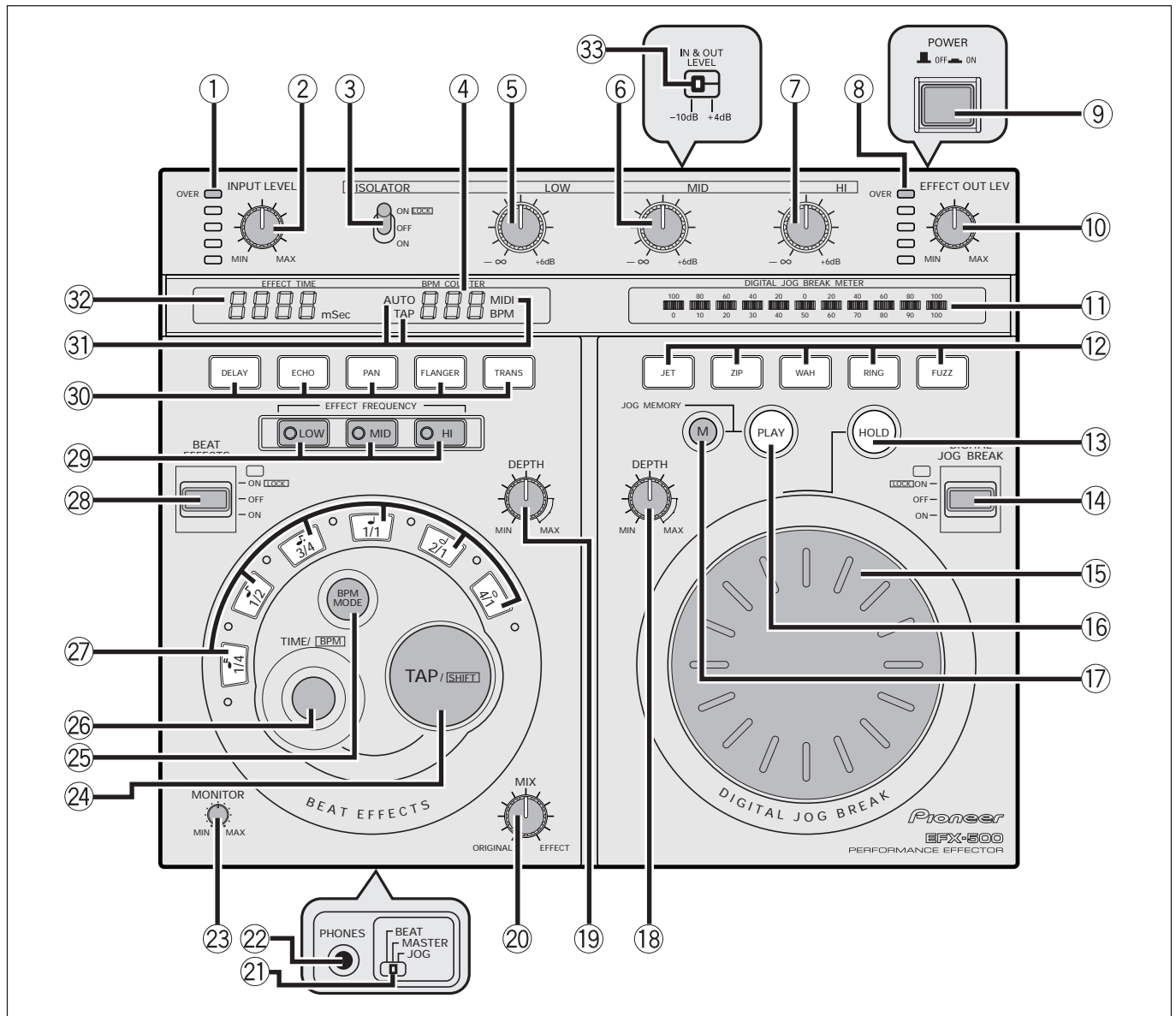

For related information on the use of each control, refer to the pages indicated within brackets “(P.XX).”

- ① **Input Level Meter (P.12)**
Indicates the input level. The “OVER” indicator lights when the input level is set too high.
- ② **INPUT LEVEL Adjust Dial (P.12)**
Adjusts the input level in the range $-\infty$ to +6 dB.
- ③ **ISOLATOR Lever Switch (P.13)**
Turns the isolator on and off. At the center position the isolator is OFF (through) and at the rear position it is ON and locked. The isolator is temporarily ON when moved to the front position and returns to the center (OFF) position when released.
- ④ **BPM COUNTER**
Gives a numeric BPM (beats per minute) indication. The counter flashes when a BPM measurement cannot be made.
- ⑤ **ISOLATOR LOW Adjustment Dial (P.13)**
Adjusts the bass of the input source. The sound is flat at the center clicked position and is cut (no sound) at the $-\infty$ position.

- ⑥ **ISOLATOR MID Adjustment Dial (P.13)**
Adjusts the mid-range of the input source. The sound is flat at the center clicked position and is cut (no sound) at the $-\infty$ position.
- ⑦ **ISOLATOR HI Adjustment Dial (P.13)**
Adjusts the treble of the input source. The sound is flat at the center clicked position and is cut (no sound) at the $-\infty$ position.
- ⑧ **Effect Output Level Meter (P.12)**
Indicates the effect output level. The “OVER” indicator lights when the output level is set too high.
- ⑨ **POWER Switch**
The POWER switch is located on the rear panel.
- ⑩ **Effect Output Level Adjust Dial (EFFECT OUT LEV) (P.12)**
Adjusts the effect output level in the range $-\infty$ to +6 dB.

- ① **DIGITAL JOG BREAK METER (P.16)**
Indicates the amount of control applied with the Jog dial.
- ⑫ **Jog Effect Select Buttons (JET/ZIP/WAH/RING/FUZZ) (P.16)**
Press to select one of 5 effects (JET, ZIP, WAH, RING or FUZZ). The selected button flashes.
- ⑬ **HOLD button (P.16)**
Press the button to light it and the effect currently applied to the sound will continue after the jog dial stops rotating.
- ⑭ **DIGITAL JOG BREAK Lever Switch (ON/OFF/LOCK-ON) (P.16)**
The Digital Jog Break sound is output when this switch is set to ON. The function is OFF when the switch is set to the center position (through). It is ON and locked at the rear position and is ON temporarily at the front position (the switch returns to the center position when released).
- ⑮ **DIGITAL JOG BREAK Dial (P.16)**
The speed of Jog dial rotation changes the amount of control applied to each effect.
- ⑯ **JOG MEMORY PLAY Button (P.17)**
Reproduces the effect created with the Jog dial that was stored in memory.
- ⑰ **JOG MEMORY Button (M) (P.17)**
Holding down this button when the Jog dial is rotated stores up to 8 seconds worth of effects created with the dial. The PLAY button ⑯ lights when effects have been saved to memory.
- ⑱ **Digital Jog Break Effect Depth Dial (DEPTH) (P.16)**
Adjusts the depth of the Digital Jog Break effect.
- ⑲ **Beat Effect Depth Dial (DEPTH) (P.15)**
Adjusts the depth of the Beat effect.
- ⑳ **MIX Dial (P.15)**
Sets the balance between the original sound and the created effect.
- ㉑ **Headphone Monitor Select Switch (BEAT/MASTER/JOG) (P.13)**
This switch is located on the front panel of the unit. Selects the source to be monitored in the headphones.
BEAT: monitors the beat effect.
MASTER: monitors the master output.
JOG: monitors the effects created with the Digital Jog Break (and the beat effect when the BEAT EFFECTS Lever Switch ㉘ is ON).
- ㉒ **Headphone Jack (PHONES)**
This jack is located on the front panel. Connect a headphone (with a 1/4-inch/6.3 mm stereo plug) to this jack.
- ㉓ **Headphone Monitor Level Dial (MONITOR)**
Adjusts the headphone sound level.
- ㉔ **Tap button (TAP/SHIFT) (P.14)**
BPM can be input manually by tapping the TAP button two times or more in time with the beat (quarter note).
When the TIME dial ㉖ is turned while this button is held down, you can directly control BPM manually.
- ㉕ **BPM Measurement Mode Button (BPM MODE) (P.14)**
Selects the BPM measurement mode (AUTO/MIDI/TAP)
AUTO: makes automatic measurements from the input music signal.
MIDI: measures BPM from the MIDI signal (timing clock) input to the MIDI IN terminal.
TAP: performs manual input of BPM when the TAP button is tapped. Pressing the TAP button in AUTO or MIDI mode changes the mode to the TAP mode.
- ㉖ **Time Dial (TIME/BPM) (P.14, 15)**
Turn this dial to set the beat effect time. When the beat effect time is changed, the indicator on the Beat Select button changes to the set position. The desired BPM setting can be made by turning the TIME/BPM dial ㉖ while holding down the TAP/SHIFT button ㉔. When the BPM MODE button ㉕ is also pressed, BPM can be set in 0.1 increments.
- ㉗ **Beat Select Buttons (1/4, 1/2, 3/4, 1/1, 2/1, 4/1) (P.15)**
Selects the beat with which the beat effect will be synchronized. When a Beat Select button is pressed, the BPM (beats per minute) effect time is automatically set.
“1/1” is selected for BPM in the TAP mode. At power on BPM is set to 120 and “1/1” is selected.
- ㉘ **BEAT EFFECTS Lever Switch (ON/OFF/ON-LOCK) (P.15)**
The beat effect sound is output when this switch is set to ON. The effect is set to OFF (through) at the center position and is ON and locked at the rear position. The effect is temporarily ON when set to the front position (the switch returns to the center position when released).
- ㉙ **EFFECT FREQUENCY Select Buttons (LOW/MID/HI) (P.15)**
Selects the frequency range to which the Beat effect is to be applied. Press the button to turn it on and off. The indicators of the selected ranges light when on. No effect is generated when all buttons are set to off.
- ㉚ **Effect Select Buttons (DELAY/ECHO/PAN/FLANGER/TRANS) (P.15)**
Select one of 5 effects (DELAY, ECHO, PAN, FLANGER or TRANS). The selected button flashes.
- ㉛ **BPM Measurement Mode Indicators (AUTO/MIDI/TAP)**
Indicates BPM measurement mode.
- ㉜ **EFFECT TIME Display**
Indicates the effect time (in ms) set with the TIME dial or Beat select button.
- ㉝ **IN & OUT LEVEL switch (+4 dB/-10dB) (P.8, 9)**
This switch is located on the rear panel.

OPERATIONS

This unit consists of three blocks: the isolator unit, beat effect unit and the digital jog break unit. Each block operates independently of each other and the effects of each can be combined.

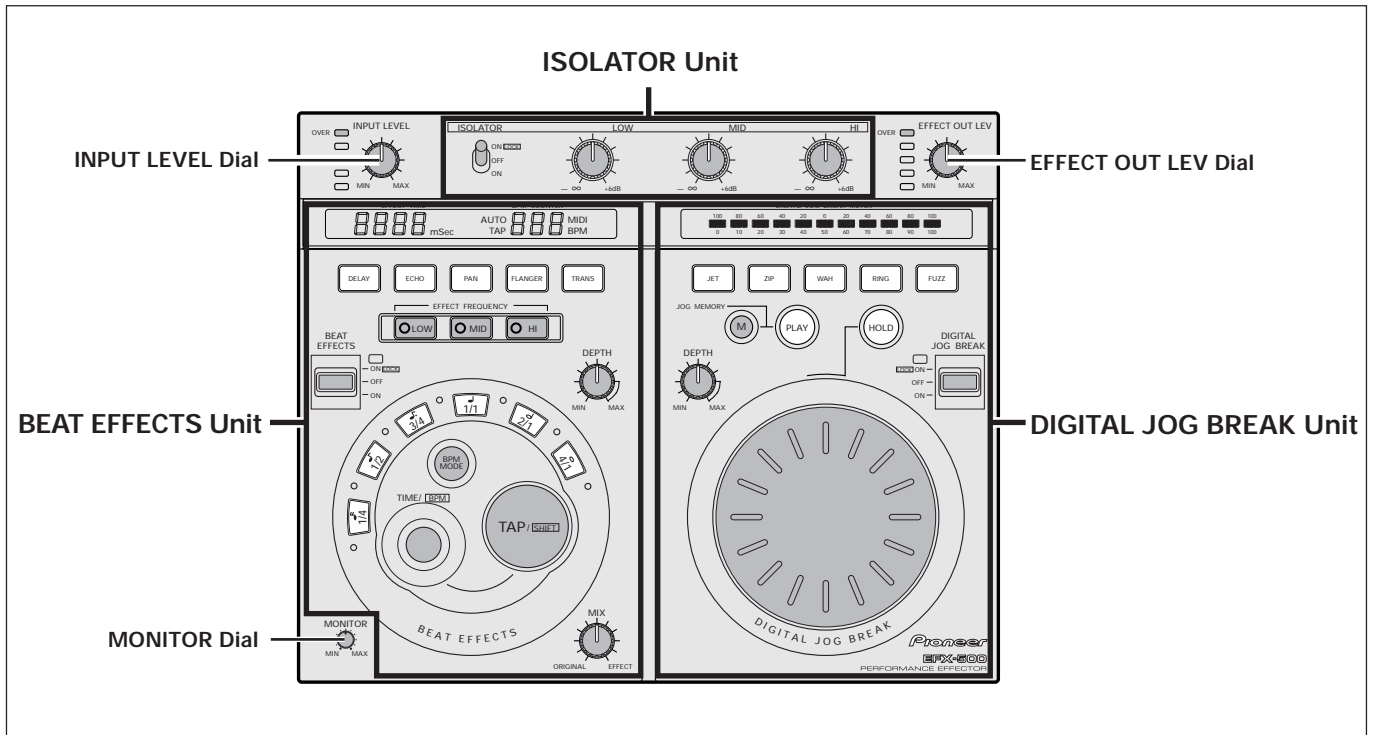

ADJUSTING INPUT LEVEL

Adjust the input level so that the sound is not distorted due to an excessive input level.

Input a signal to the input terminal and turn the INPUT LEVEL dial to the position right before the "OVER" indicator on the level meter lights.

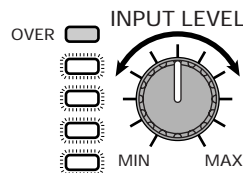

- Change the setting (-10 dB/+4 dB) of the IN & OUT LEVEL switch on the rear panel when a desired setting can be achieved only by setting the INPUT LEVEL dial to "MIN" or close to "MAX".

ADJUSTING EFFECT OUTPUT LEVEL

Adjusts the sound level of the effect applied to the input sound signal by the Digital Jog dial and the beat effect.

Turn the EFFECT OUT LEV dial to the position right before the "OVER" indicator on the level meter lights.

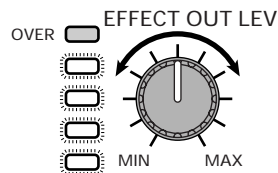

- When both the BEAT EFFECTS Lever switch and the DIGITAL JOG BREAK Lever switch are set to OFF, the output level is not changed by turning the EFFECT OUT LEV dial.

HEADPHONE MONITOR

This function allows you to monitor (pre-listen) sound effects (the sound normally output through the output terminals) without routing the sound through the output terminal.

1 Connect the headphone plug to the headphone jack (PHONES) on the front panel.

- Use a headphone with a standard 1/4-inch/6.3 mm stereo plug.

2 Select the source to be monitored with the Headphone Monitor Select switch.

BEAT: beat effect
MASTER: same sound as that output by the output terminals
JOG: Digital Jog Break sound

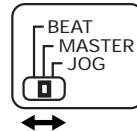

- The Headphone Monitor Select switch is located beside the Headphone Jack on the front panel.
- When the Headphone Monitor Select switch is set to "JOG" and the BEAT EFFECTS Lever switch is set to ON, the beat effect and the digital jog break sound are both generated.
- ECHO cannot be monitored when the BEAT EFFECTS lever switch is set to "OFF." Should this be the case, switch the effect to DELAY to obtain the same effect.

3 Adjust the headphone volume with the MONITOR dial.



ISOLATOR

The isolator divides the sound range into three distinct levels which can be separately controlled.

1 Use the LOW, MID and HI dials to adjust the sound level.

LOW: bass drum, bass, etc.
MID: vocals, guitar, etc.
HI: cymbals, highhats, etc.

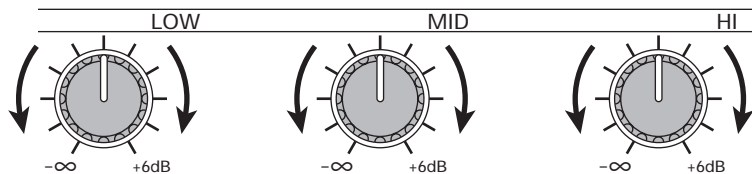

- The level is flat at the center clicked position and off at the $-\infty$ position.

2 Turn on the isolator by setting the ISOLATOR lever switch to ON.

Front position (ON): the isolator is on as long as the switch is held at this position and returns to the center (OFF) position when released. Use this position for flicking between the ON and OFF positions.

Rear position (ON-LOCK): the isolator is on and locked; the function is in effect also when the switch is released. Turn off the function by returning the switch to the center (OFF) position.

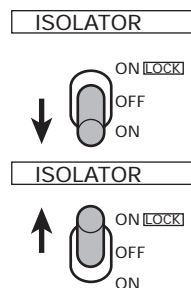

- When the ISOLATOR lever switch is set to OFF, the original sound is unaffected.

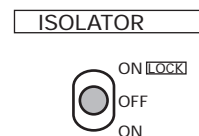

- No sound is produced when the LOW, MID and HI dials are all set to $-\infty$ position and the ISOLATOR lever switch is set to ON.

BEAT EFFECT

Since the beat effect time of the beat effect can be synchronized in real-time with the BPM (beats per minute), you can easily generate effects in time with the rhythm of a live performance.

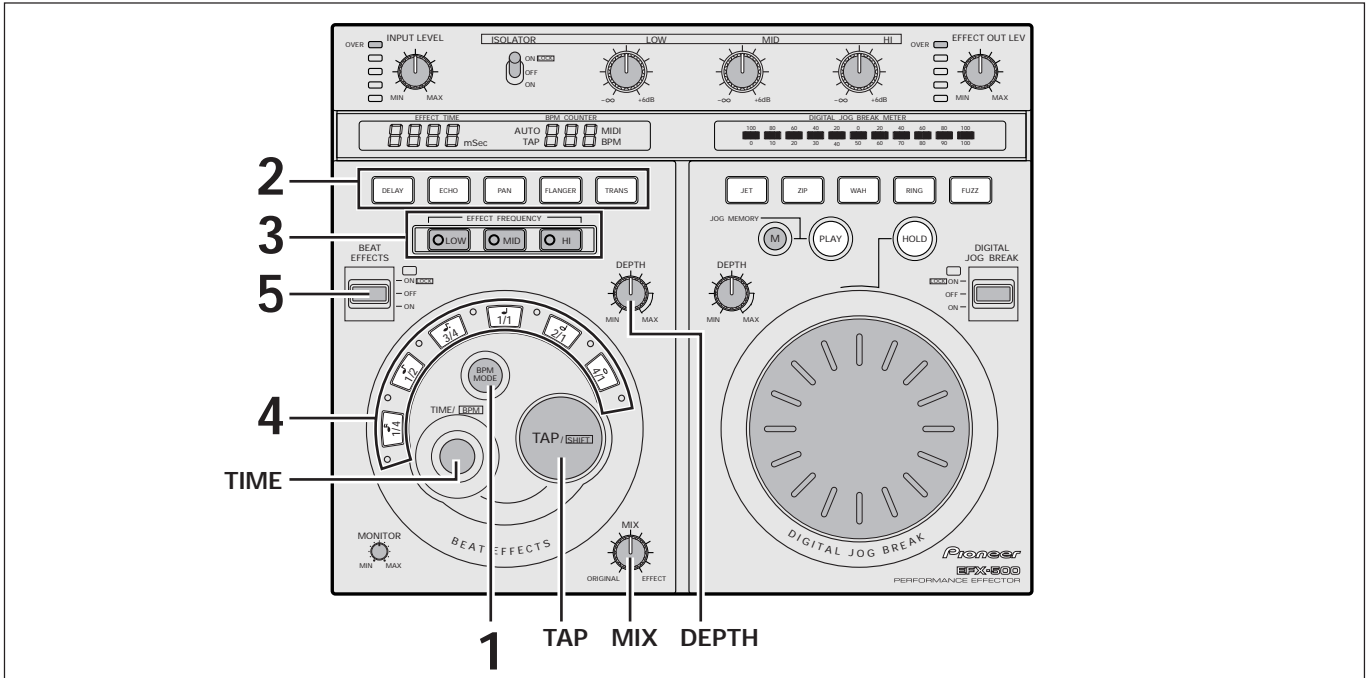

1 Press the BPM MODE button to select BPM (beats per minute) measurement mode.

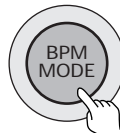

AUTO: performs automatic measurement from the input music signal.

MIDI: measures BPM from the MIDI signal (timing clock) input to the MIDI IN terminal

TAP: allows manual BPM input when the TAP button is tapped with the fingers.

- The selected BPM measurement mode indicator lights.
- The BPM COUNTER flashes when BPM measurement cannot be made.
- The BPM measurement range is 70 to 180 in the AUTO mode. It may not be possible to measure some tunes correctly. Should this happen, use the TAP mode to make a manual input.
- The BPM measurement range is 40 to 250 in the MIDI mode.
- Pressing the TAP button in BPM AUTO or MIDI mode changes the mode to the TAP mode.
- When BPM is set with the TAP button, the Beat Effect Select button 1/1 is selected and the time of 1 beat (quarter notes) is set to the effect time.

Manual BPM input using the TAP button

When the TAP button is tapped two or more times in time with the beat (quarter notes), the average value of the intervals is used to set BPM.

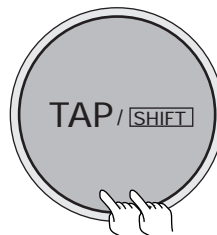

Manual BPM input using the TIME dial

BPM can be directly set by turning the TIME dial when the TAP button is held down.

- BPM can be set in 0.1 increments by pressing the BPM MODE button and turning the TIME dial while holding down the TAP button. Only decimal values are shown at this time.

Example: 120.4

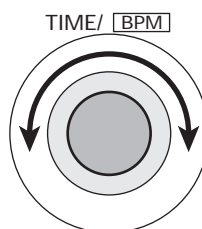
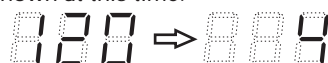

2 Select the effect type with the Effect Select buttons.



- The selected effect button flashes.
- See page 6 for further information on each effect.

3 Select the frequency range to which the effect is to be applied with the EFFECT FREQUENCY buttons (LOW, MID, HI).

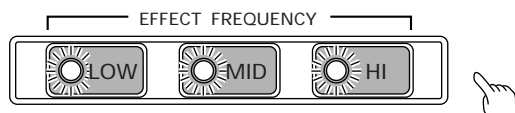

- The indicator of the selected frequency range lights.
- The function is turned on and off each time the button is pressed.

4 Press one Beat Select button to select the beat with which the effect is to be synchronized.

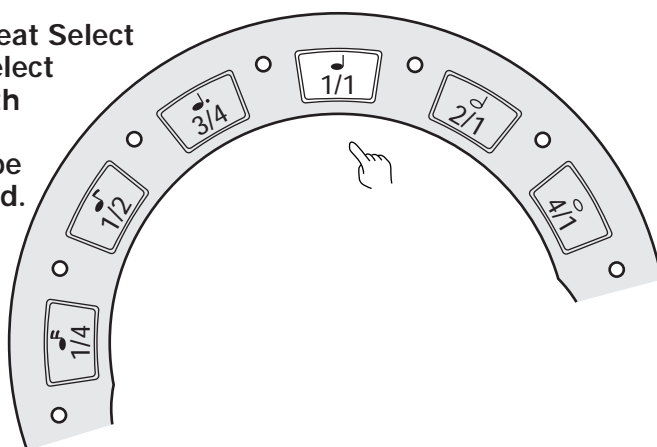

- The selected Beat button lights.
- When a beat button is pressed, the corresponding effect time is automatically set.
Example: when BPM is 120,
1/1 → 500 ms
3/4 → 375 ms
1/2 → 250 ms
- When the Beat select button is pressed and the TAP button is held down, BPM is automatically set from the effect time.

Manual Input of Effect Time Using the TIME Dial

Normally, the effect time is automatically set when a beat button is pressed. However, the effect time can be set as desired using the TIME dial.

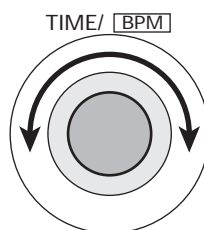

- When the effect time is changed, the indicator of the selected beat effect button lights.

5 Set the BEAT EFFECTS Lever switch to ON to start operation.

Rear position (ON-LOCK): the effect is on and locked and remains in effect also when the switch is released. Turn off the function by returning the switch to the center (OFF) position.

Front position (ON): the effect is on as long as the switch is held at this position and returns to the center (OFF) position when released. Use this position for flicking between the ON and OFF positions.

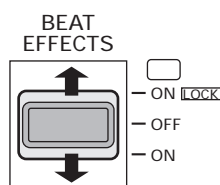

- When the Lever switch is off, the original sound is unaffected.

DEPTH Dial

A standard effect is produced at the center clicked position. The parameter changes produced by turning the DEPTH dial are described on page 6.

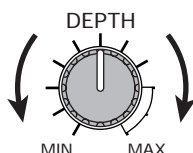

MIX Dial

This dial adjusts the balance between the original sound and the effect. A standard effect is produced at the center clicked position. The parameter changes produced by turning the MIX dial are described on page 6.

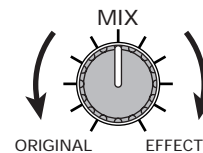

DIGITAL JOG BREAK

Since the Digital Jog Break can continuously change the parameters of each effect generated by rotating the Jog dial, the effects can be controlled like a musical instrument. Effects generated with the Jog dial can be continuously stored in memory and can be reproduced any number of times at the press of the PLAY button.

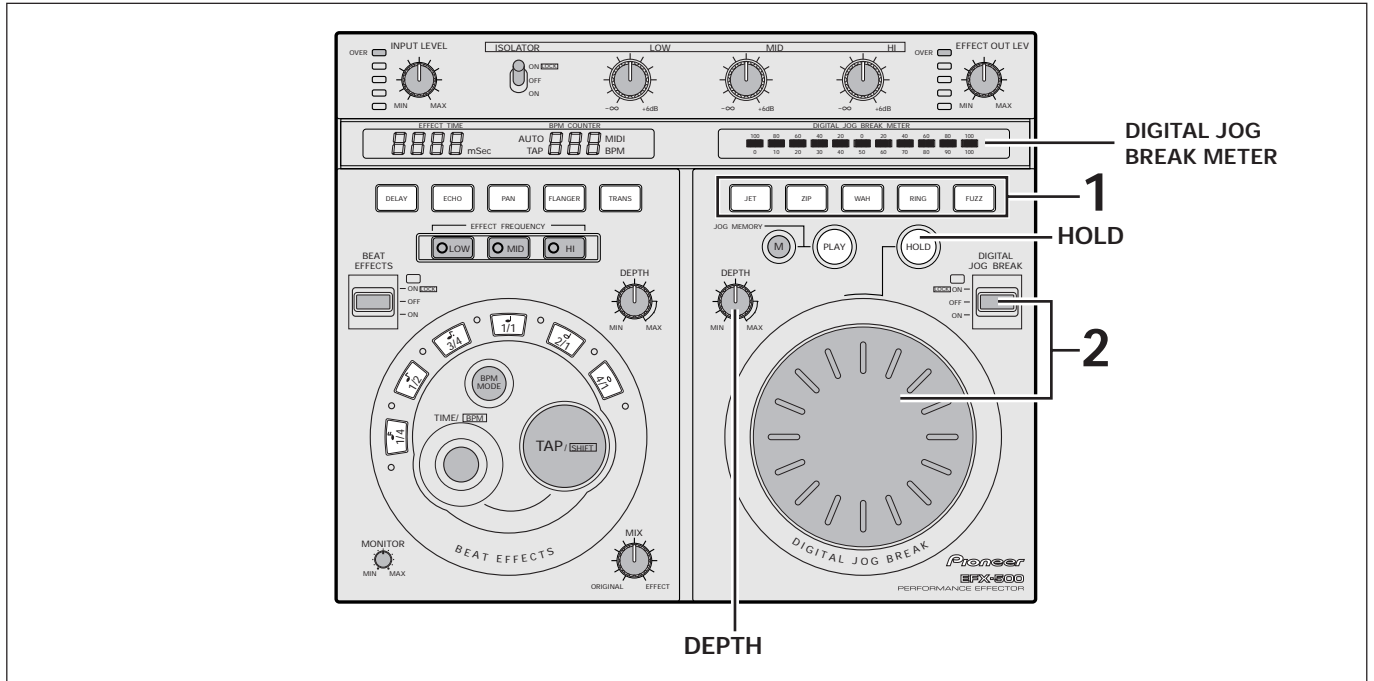

1 Select the type of effect to be produced by pressing a Jog Effect Select button.



- The selected jog effect button flashes.
- See page 7 for a description of each effect.

2 Set the DIGITAL JOG BREAK Lever switch to ON and turn the Jog dial.

DIGITAL JOG BREAK Lever switch operation

Rear position (LOCK-ON): the effect is on and locked and remains in effect also when the switch is released. Turn off the function by returning the switch to the center (OFF) position.

Front position (ON): the effect is on as long as the switch is held at this position and returns to the center (OFF) position when released. Use this position for flicking between the ON and OFF positions.

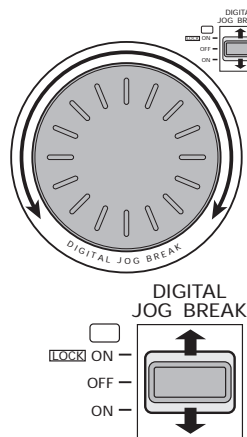

- When the Lever switch is set to OFF, the original sound is unaffected.
- Parameter changes caused by rotating the Jog dial are indicated on the DIGITAL JOG BREAK METER.

DEPTH Dial

A standard effect is produced at the center clicked position. The parameter changes produced by turning the DEPTH dial are described on page 7.

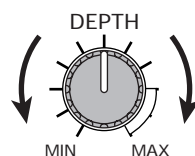

HOLD Function
When the HOLD button is pressed and lit, the effect generated by the rotation of the Jog dial continues when the dial rotation stops.

JOG MEMORY

The memory can store up to 8 seconds of effects generated by the Jog dial of the Digital Jog Break function.

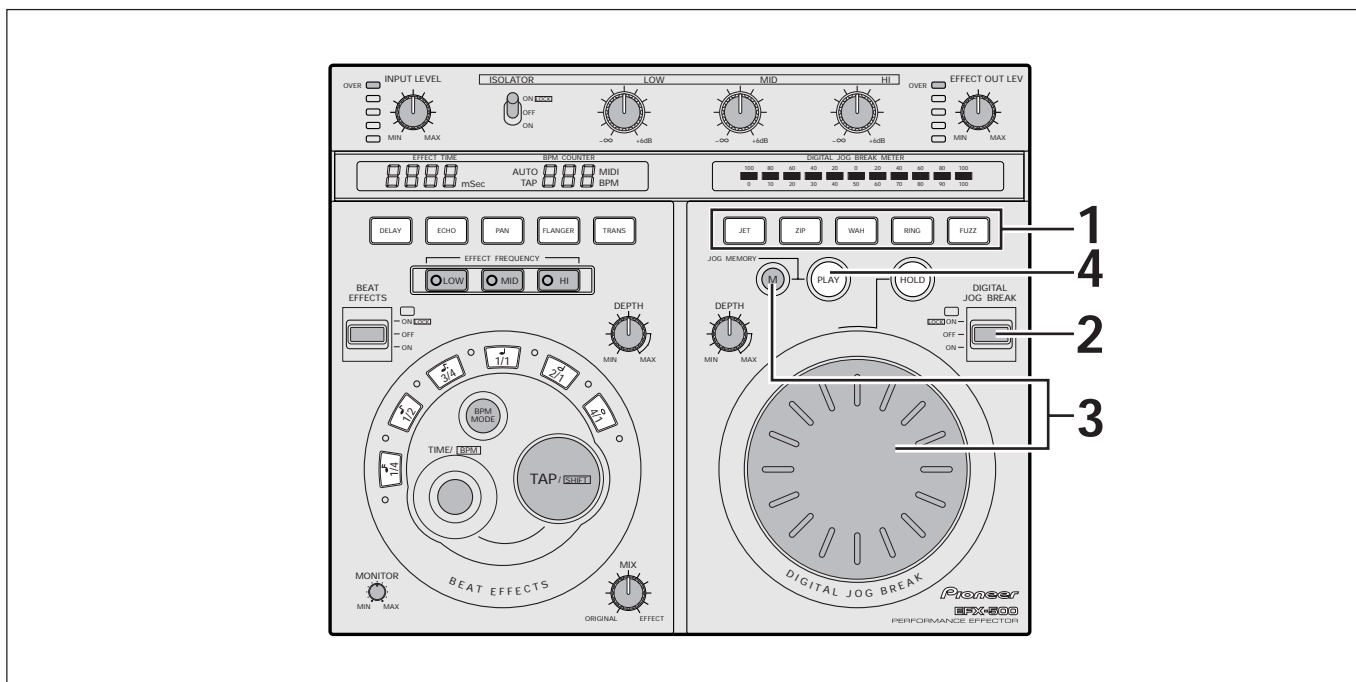

1 Press a Jog Effect Select button to select the type of effect.



- The selected effect button flashes.
- See page 7 for a description of each effect.

2 Set the DIGITAL JOG BREAK Lever switch to ON to monitor the effect.

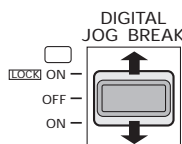

- When the Headphone Monitor Select switch is set to JOG, it can monitor the effects even if the Lever switch is set to OFF.

3 Turn the Jog dial while holding down the JOG MEMORY button (M).
Turning the Jog dial while the M button is held down starts memory storage. Effects are stored continues for 8 seconds or until the M button is released. The PLAY button lights.

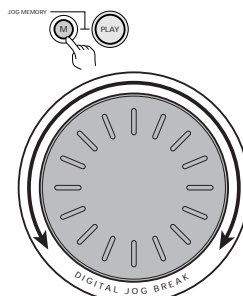

- When an effect has been stored (and the PLAY button is lit), the storing of a new effect will overwrite the old effect (delete it).

4 Press the JOG MEMORY PLAY Button.
The stored effect is played back once for as long as the button is pressed.



- The effects stored in memory can be repeatedly reproduced by repeatedly pressing the PLAY button.
- Jog dial operation stored in memory can be reproduced even when the type of effect is subsequently changed.

MIDI SETTINGS

MIDI (Musical Instrument Digital Interface) is a standard that unifies data exchanges between musical instruments and computers.

This interface allows equipment with MIDI connectors to be connected with MIDI cables to allow data transmission and reception. The EFX-500 can transmit and receive BPM data (timing clock) using MIDI.

SYNCHRONIZING AN EXTERNAL SEQUENCER USING AUDIO SIGNALS

An external sequencer can be synchronized with rhythms generated by a CD player or other unit.

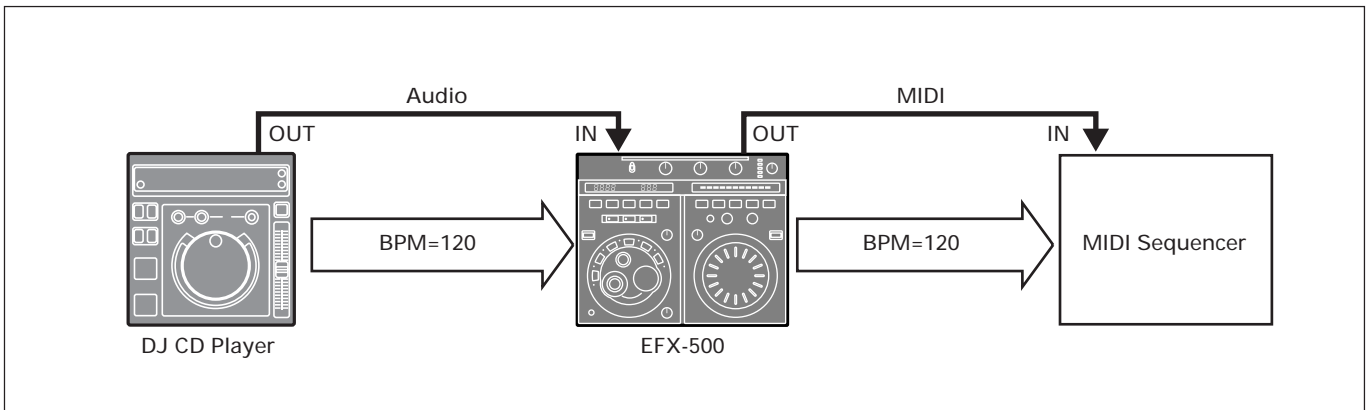

[Step 1]

Connect the MIDI OUT terminal on the EFX-500 to the MIDI IN terminal on the MIDI sequencer using a commercially available MIDI cable.

- Set the MIDI sequencer to the slave synchronizing mode.
- A MIDI sequencer that does not support the MIDI timing clock cannot be synchronized.

[Step 2]

Press the BPM MODE button to invoke the AUTO mode.

- Tunes that do not allow stable BPM value measurements cannot be synchronized.
- Also BPM values set in the TAP mode output a timing clock.

[Step 3]

Press the Start button on the MIDI sequencer in time with the beat of the tune.

- The EFX-500 synchronizes the quarter notes of the bass drum as the standard timing.
- The output range of the MIDI timing clock is BPM 40 to 250.
- MIDI start and stop signals are not output.

NOTE:

BPM may not be correctly measured for some tunes.

SYNCHRONIZING BEAT EFFECT TO AN EXTERNAL SEQUENCER

The EFX-500 beat effect can be synchronized with the rhythms generated by an external sequencer.

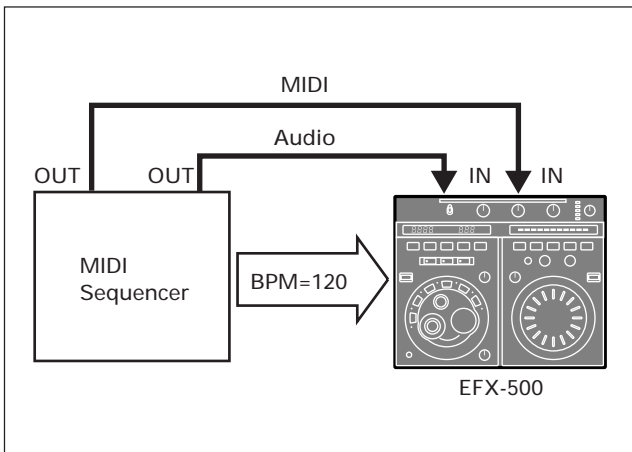

[Step 1]

Connect the MIDI OUT terminal on the MIDI sequencer to the MIDI IN terminal on the EFX-500 using a commercially available MIDI cable.

- Set the MIDI sequencer to the master synchronizing mode.

[Step 2]

Press the BPM MODE button to invoke the MIDI mode.

- In MIDI mode, the original sound in MIDI OUT terminal is unaffected and data input to the MIDI IN terminal is output.

[Step 3]

Start the MIDI sequencer and press the Beat button on the EFX-500 to set the effect time.

- The input range of the MIDI timing clock is BPM 40 to 250.

NOTE:

When the MIDI sequencer is set in 0.1 increments, The BPM indication may differ on the EFX-500.

TROUBLESHOOTING

Incorrect operation can be mistaken for a malfunction. If you believe the unit is not operating correctly, consult the chart below. Sometimes incorrect operation may be due to a malfunction in another component. If the problem cannot be solved using the information in the chart, check the other components used with the unit. If the problem still persists, contact your nearest authorized Pioneer service center.

Symptom	Remedy
No effect is generated.	Turn the MIX dial clockwise (in "EFFECT" direction). Turn the DEPTH dial clockwise (in "MAX" direction). Turn the EFFECT OUT LEV dial clockwise (in "MAX" direction).
The effect is distorted.	Turn the INPUT LEVEL dial counterclockwise (in "MIN" direction). Turn the EFFECT OUT LEV dial counterclockwise (in "MIN" direction). Turn the DEPTH dial counterclockwise (in "MIN" direction).
Echo is output continuously.	Turn the DEPTH dial counterclockwise (in "MIN" direction).
BPM cannot be measured in the AUTO mode.	The measurement range is 70 to 180. It may not be possible to measure some tunes. Invoke the TAP mode and make a manual setting (see P. 14).
The MIDI sequencer is not synchronized.	Set the MIDI sequencer mode to slave mode. A MIDI sequencer that does not support the MIDI timing clock cannot be synchronized.
The sound cannot be monitored via the headphones.	Turn the MONITOR dial clockwise (towards the "MAX" position). ECHO cannot be monitored when the BEAT EFFECTS lever switch is set to "OFF." Should this be the case, switch the effect to DELAY to obtain the same effect.

- Static electricity and other external influences may cause this unit to malfunction. Should this happen, disconnect the power plug, wait for 30 seconds and connect the power plug again. If this does not solve the problem, contact your nearest authorized Pioneer service center.

SPECIFICATIONS

1. General

Power supply 120 V AC, 60 Hz
 Power consumption 14 W
 Operating temperature +5°C to +35°C
 (+41°F to +95°F)
 Weight 2.0 kg (4.4 lb)
 Maximum external dimensions
 277.1 (W) x 225.1 (D) x 83.5 (H) mm
 10-29/32 (W) x 8-7/8 (D) x 3-5/16 (H) in.

2. Audio Unit

Sampling rate 48 kHz
 A/D, D/A Resolution 20 bits
 Frequency characteristics 20 Hz to 22 kHz
 S/N ratio 83 dB
 Total harmonic distortion 0.01 % or less
 Input level -10 dBu / +4 dBu (22 kΩ)
 Output level -10 dBu / +4 dBu
 (RCA pin jacks: 1 kΩ, Phone jacks: 600 Ω)
 *-10 dBu / +4 dBu is switchable.
 Number of channels 2 channels (stereo)

3. Input/Output terminals

Audio line output terminal
 RCA pin jacks 2
 Phone jacks (1/4-inch/6.3 mm in diameter) 2
 Audio line input terminal
 RCA pin jacks 2
 Phone jacks (1/4-inch/6.3 mm in diameter) 2
 MIDI output terminal (5-pin DIN) 1
 MIDI input terminal (5-pin DIN) 1
 Headphone output terminal
 (1/4-inch/6.3 mm in diameter, stereo) 1

4. Accessories

Operating instructions 1
 Guide plate 1
 Warranty card 1

NOTE:

Specifications and design are subject to possible modification without notice.

This equipment has been tested and found to comply with the limits for a Class B digital device, pursuant to Part 15 of the FCC Rules. These limits are designed to provide reasonable protection against harmful interference in a residential installation. This equipment generates, uses, and can radiate radio frequency energy and, if not installed and used in accordance with the instructions, may cause harmful interference to radio communications. However, there is no guarantee that interference will not occur in a particular installation. If this equipment does cause harmful interference to radio or television reception, which can be determined by turning the equipment off and on, the user is encouraged to try to correct the interference by one or more of the following measures:

- Reorient or relocate the receiving antenna.
- Increase the separation between the equipment and receiver.
- Connect the equipment into an outlet on a circuit different from that to which the receiver is connected.
- Consult the dealer or an experienced radio/TV technician for help.

Should this product require service in the U.S.A. and you wish to locate the nearest Pioneer Authorized Independent Service Company, or if you wish to purchase replacement parts, operating instructions, service manuals, or accessories, please call the number shown below.

800 – 872 – 4159

Please do not ship your product to Pioneer without first calling the Customer Service Department at the above listed number for assistance.

**PIONEER ELECTRONICS SERVICE, INC.
CUSTOMER SUPPORT DIVISION
P.O. BOX 1760, LONG BEACH,
CA 90801-1760, U.S.A.**

For warranty information please see the Limited Warranty sheet included with your product.

Should this product require service in Canada, please contact a Pioneer Canadian Authorized Dealer to locate the nearest Pioneer Authorized Service Company in Canada. Alternatively, please contact the Customer Service Department at the following address:

Pioneer Electronics of Canada, Inc.

**300 Allstate Parkway
Markham, ON L3R OP2
(905) 479-4411**

For warranty information please see the Limited Warranty sheet included with your product.



Dear Customer:

Selecting fine audio equipment such as the unit you've just purchased is only the start of your musical enjoyment. Now it's time to consider how you can maximize the fun and excitement your equipment offers. This manufacturer and the Electronic Industries Association's Consumer Electronics Group want you to get the most out of your equipment by playing it at a safe level. One that lets the sound come through loud and clear without annoying blaring or distortion-and, most importantly, without affecting your sensitive hearing.

Sound can be deceiving. Over time your hearing "comfort level" adapts to higher volumes of sound. So what sounds "normal" can actually be loud and harmful to your hearing. Guard against this by setting your equipment at a safe level BEFORE your hearing adapts.

To establish a safe level:

- Start your volume control at a low setting.
- Slowly increase the sound until you can hear it comfortably and clearly, and without distortion.

Once you have established a comfortable sound level:

- Set the dial and leave it there.

Taking a minute to do this now will help to prevent hearing damage or loss in the future. After all, we want you listening for a lifetime.

We Want You Listening For A Lifetime

Used wisely, your new sound equipment will provide a lifetime of fun and enjoyment. Since hearing damage from loud noise is often undetectable until it is too late, this manufacturer and the Electronic Industries Association's Consumer Electronics Group recommend you avoid prolonged exposure to excessive noise. This list of sound levels is included for your protection.

Decibel

Level	Example
30	Quiet library, soft whispers
40	Living room, refrigerator, bedroom away from traffic
50	Light traffic, normal conversation, quiet office
60	Air conditioner at 20 feet, sewing machine
70	Vacuum cleaner, hair dryer, noisy restaurant
80	Average city traffic, garbage disposals, alarm clock at two feet.

THE FOLLOWING NOISES CAN BE DANGEROUS UNDER CONSTANT EXPOSURE

90	Subway, motorcycle, truck traffic, lawn mower
100	Garbage truck, chain saw, pneumatic drill
120	Rock band concert in front of speakers, thunderclap
140	Gunshot blast, jet plane
180	Rocket launching pad

Information courtesy of the Deafness Research Foundation.



Published by Pioneer Electronic Corporation.
Copyright © 1998 Pioneer Electronic Corporation.
All rights reserved.

PIONEER ELECTRONIC CORPORATION 4-1, Meguro 1-Chome, Meguro-ku, Tokyo 153-8654, Japan
PIONEER NEW MEDIA TECHNOLOGIES, INC. 2265 East 220th Street, Long Beach, California 90810, U.S.A.
PIONEER ELECTRONICS OF CANADA, INC. 300 Allstate Parkway, Markham, Ontario L3R OP2, Canada